



G Series 24" Gas Restaurant Range

Item: _____
 Quantity: _____
 Project: _____
 Approval: _____
 Date: _____

G Series 24" Gas Restaurant Range

Models:

- G24-4L G24-4S G24-2G12L G24-2G12S G24-G24L G24-G24S



Model G24-4L

NOTE: Ranges supplied with casters must be installed with an approved restraining device.

Standard Features:

- Large 27" (686mm) work top surface
- Stainless steel front and sides
- Stainless steel 5" (127mm) plate rail
- Stainless steel backguard, w/removable stainless steel shelf
- 12" (305mm) section stamped drip trays w/ dimpled bottom
- 6" (152mm) adj. stainless steel legs
- Large easy-to-use control knobs
- Gas regulator

Standard on Applicable Models:

- Cabinet base in lieu of oven
- Ergonomic split cast iron top ring grates
- 33,000 Btuh/ 9.67 kW 2 piece cast iron Starfire- Pro open top burner
- 5/8" (15mm) thick steel griddle plate w/manual hi/lo valve control, 23" (584mm) working depth surface, Standard on right, optional on left
- 4-1/4" (108mm) wide grease trough
- 18,000 Btuh/5.27 kW cast iron "H" style griddle burner per 12"(305mm) width of griddle
- 32,000 Btuh/9.38 kW cast iron "H" style oven burner

- Snap action modulating oven thermostat low to 500° F
- Space saver oven w/ porcelain interior
- Nickel plated oven rack and 3-position removable oven rack guide
- Strong, keep-cool oven door handle

Optional Features:

- Snap action modulating griddle control 175° to 425° F
- Grooved griddle in 1/2 or full plate section widths
- Hot top 12" (305mm) plate in lieu of two open burners, manual valve controlled w/18,000 Btuh/5.27 kW cast iron "H" burner standard on left side
- Low profile 9-3/8" (238mm) backguard stainless steel front and sides
- Stainless steel back for high shelf, low profile backguard or range
- Additional oven racks
- 6" (152mm) levelling swivel casters (4), w/front locking
- Flanged deck mount legs
- Stainless steel door for storage base models
- Intermediate stainless steel shelf for storage base models
- Celsius temperature dials

Specifications:

Gas restaurant series range with space saver oven. 23-5/8" (600mm) wide and 27" (686mm) deep work top surfaces. Stainless steel front, sides and 5" wide front rail. 6" (152mm) legs with adjustable feet. Four Starfire-Pro 2 piece, 33,000 Btuh/ 9.67 kW (natural gas), cast open burners set in split cast iron ergonomic grates. Griddle or optional hot top with cast iron "H" style burners, 18,000 Btuh/5.27 kW (natural gas), in lieu of open burners. One piece oven with porcelain interior and heavy duty, "keep cool" door handle. Heavy cast iron "H" 32,000 Btuh/ 9.38 kW (natural gas) oven burner controlled by even bake, fast recovery snap action modulating oven thermostat. Available with storage base in lieu of oven



Garland Commercial Industries, LLC
 185 East South Street
 Freeland, PA 18224
 Phone: (570) 636-1000
 Fax: (570) 636-3903

Garland Commercial Ranges Ltd
 1177 Kamato Road,
 Mississauga, Ontario
 L4W 1X4 CANADA
 Phone: 905-624-0260
 Fax: 905-624-5669



Model Number	Description	Total BTU/Hr Natural Gas	Shipping Information		
			Lbs.	Kg	Cu. Ft.
G24-4L	Four Open Burners w/Space Saver Oven	164,000	302	137	26
G24-4S	Four Open Burners w/Storage base	132,000	221	100	26
G24-2G12L	12" Griddle, Two Open Burners w/Space Saver Oven	116,000	332	151	26
G24-2G12S	12" Griddle, Two Open Burners w/Storage base	84,000	251	114	26
G24-24GL	24" Griddle w/Space Saver Oven	68,000	367	166	26
G24-24GS	24" Griddle w/Storage Base	36,000	286	130	26

Width	Depth	Height w/Shelf	Oven Interior			Combustible Wall Clearance		Entry Clearances	
			Height	Depth	Width	Sides	Rear	Crated	Uncrated
23-5/8" [600mm]	34-1/2" [876mm]	57" [1448mm]	13" [330mm]	26" [660mm]	20" [508mm]	14" [356mm]	6" [152mm]	25" [635mm]	24-1/2" [622mm]

Burner Ratings (BTU/Hr/kW)			
Gas	Open	Griddle/Hot Top	Oven
Natural	33,000/9.67	18,000/5.27	32,000/9.38
Propane	26,000/7.61	18,000/5.27	28,000/8.20

Manifold Operating Pressure	
Natural	Propane
4.5" WC/11 mbar	10.0" WC/25 mbar

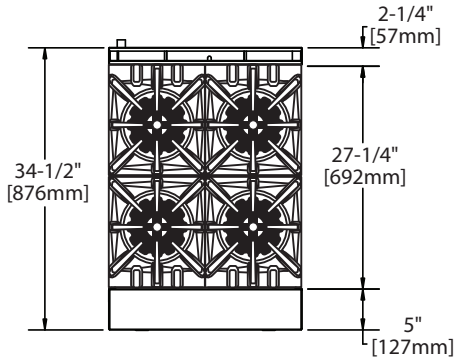

Note: Installation clearance reductions are applicable only where local codes permit.

Gas input ratings shown for installations up to 2000 ft.,(610m) above sea level. Please specify altitudes over 2000 ft.

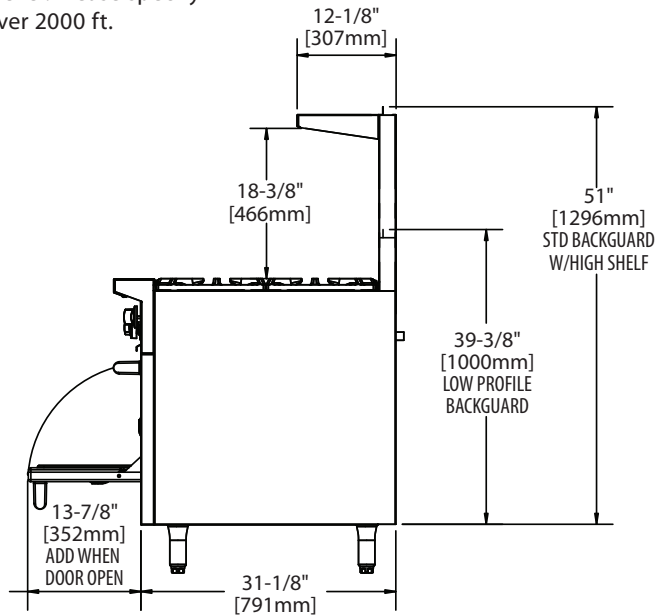
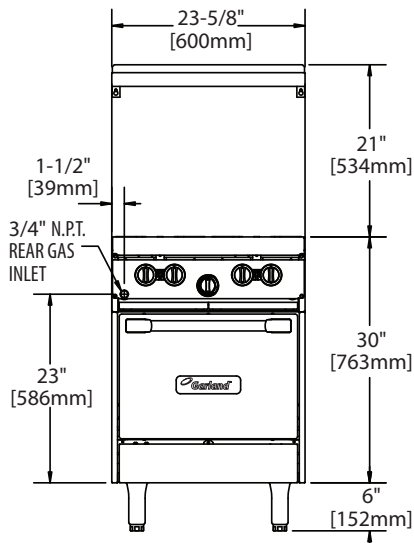

This product is not approved for residential use.

Form# 24" G series (02/03/09)